

MODEL 257

3-Phase Monitor

- Detects phase loss, low voltage, phase reversal
- 50 Hz, 60 Hz and 400 Hz models
- Automatic or manual reset
- Five year unconditional warranty



DESCRIPTION

The **Model 257** continuously monitors 3-phase power lines for abnormal conditions. When properly adjusted, the Model 257 monitor will detect phase loss on a loaded motor even when regenerated voltage is present.

This device consists of a solid-state voltage and phase-angle sensing circuit, driving an electro-mechanical relay. When correct voltage and phase rotation are applied, the internal relay will energize. A fault condition will de-energize the relay. When the fault is corrected, the monitor will automatically reset (*a manual reset version is also available*).

The Model 257 does not require a neutral connection and can be used with Wye or Delta systems. Voltage ranges are sufficiently wide to allow for proper adjustment to existing conditions. Both "TRIP" and "NORM" condition indicators are provided to aid in adjustment and system trouble-shooting.

TYPICAL APPLICATION

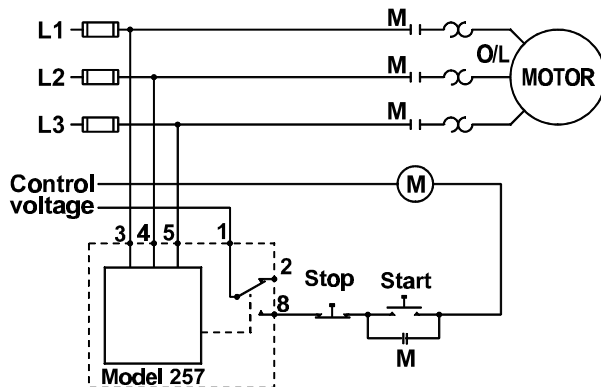

SPECIFICATIONS

AUTO Reset MANUAL Reset	B257B B257BM	257B 257BM	A257B A257BM	EX257B EX257BM	B257B-400 B257BM-400	257B-400 257BM-400
Nominal AC voltage (phase to phase)	120 vac	208/240 vac	480 vac	380 vac	120 vac	208/240 vac
Case Color	Gray	Red	Yellow	Yellow	Gray	Red
Adjustment range	85-120vac	160-240vac	380-480vac	300-400vac	85-120vac	160-240vac
Frequency	60 Hz	60 Hz	60 Hz	50 Hz	400 Hz	400 Hz
Power consumption	0.75W	1.5W	4.5W	3.75W	0.75W	1.5W
Transient protection	2500 VAC for 10msec					
Repeat accuracy	± 0.1% of set point (fixed conditions)					
Response time	50 msec (set or reset)					
Dead band	Approximately 2%					
Output contacts	SPDT 10 amps at 240 VAC resistive					
Expected relay life	Mechanical: 10 million operations Electrical: 100,000 operations at rated load					
Operating temp	-40° to +131° F					
Humidity tolerance	0 - 97% w/o condensation					
Enclosure material	Dust cover: ABS plastic					
Mounting	8-pin socket (**sold separately)					
Weight	5 ounces					
Agency approvals	UL Recognized* and CSA Certified *condition of acceptability: the 380V and 480V versions must be used with a UL Recognized 600 VAC socket					

** Order 8-pin socket number 51X120

DIMENSIONS

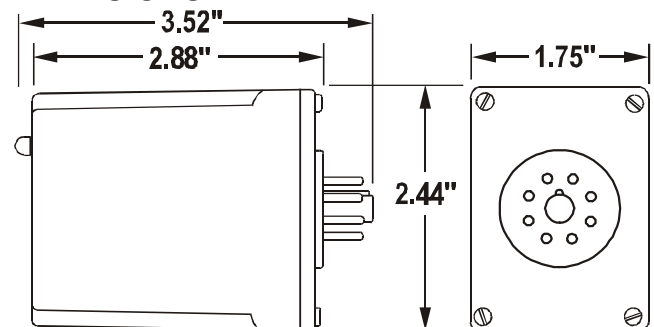

(dimensions have tolerance of ± 0.06)



TIME MARK
CORPORATION

Doc No. 87A189 12/00
© 2000 TIME MARK CORPORATION

TIME MARK is a division of  AEMT, Inc.

MODEL 257

3-Phase Monitor

READ ALL INSTRUCTIONS BEFORE INSTALLING, OPERATING OR SERVICING THIS DEVICE.
KEEP THIS DATA SHEET FOR FUTURE REFERENCE.

GENERAL SAFETY

POTENTIALLY HAZARDOUS VOLTAGES ARE PRESENT AT THE TERMINALS OF THE MODEL 257.
ALL ELECTRICAL POWER SHOULD BE REMOVED WHEN CONNECTING OR DISCONNECTING WIRING.
THIS DEVICE SHOULD BE INSTALLED AND SERVICED BY QUALIFIED PERSONNEL.

Installation Instructions

WARNING

IN APPLICATIONS WHERE VOLTAGES IN EXCESS OF 300 VAC ARE TO BE MONITORED, BE CERTAIN TO USE THE TIME MARK MODEL 51X120 8-PIN SOCKET, OR AN EQUIVALENT UL APPROVED 600 VAC RATED SOCKET.

INSTALLATION

Mount the 8-pin socket in a suitable enclosure. A NEMA-1 rated enclosure, designed for socket-mounted relays is available from Time Mark Corporation.

Connect 3-phase power to terminals 3, 4, and 5 on the socket. Phase rotation should be verified using a Time Mark Model 108A or 108B Phase Sequence Detector.

Connect the load control wiring to the appropriate terminals on the socket:

For motor control applications; use terminals 1 and 8.

For phase loss alarm applications; use terminals 1 and 2.

Insert the Model 257 into the socket and apply power. If the contact does not transfer (green light ON), check that all phases are present, and of the correct voltage. If power is correct, rotate the level adjustment counter-clockwise.

If the contact still does not transfer, remove power and reverse two of the three phase wires at the socket (*phase rotation is reversed*). Re-apply power. The contact should transfer to provide a signal path between pins 1 and 8.

NOTE: When installing the Model 257 monitor in areas of high humidity or contamination, it is recommended that the base area and all exposed metal parts of the socket be coated liberally with a good quality silicon grease, such as Dow Corning DC-4 or DC-4X. Insert the unit into the socket and wipe off excess grease around the base. This will prevent the entrance of moisture and other contaminants into the base and socket areas.

ADJUSTMENT SETTINGS

The following procedure will allow the Model 257 to be adjusted to achieve a trip point just below the nominal phase-to-phase voltage, where the unit is applied.

Rotate the adjustment control fully clockwise, or until the red (TRIP) indicator illuminates.

Slowly rotate the adjustment control in a counter-clockwise direction, just until the green (NORM) indicator illuminates.

At this point, the Model 257 is the most sensitive to irregular power line conditions. If nuisance tripping occurs, turn the control slightly farther counter-clockwise.

A more accurate setting will require the use of a 3-phase variac to lower the voltage to an exact measurable setting. Time Mark also offers a factory set version of all models and voltage ranges, for only a small additional charge.

TROUBLESHOOTING

Should the Model 257 Monitor fail to operate properly, check that all three voltages are present, and are of the correct voltage level and phase rotation (a Model 108A or 108B Phase Sequence Detector should be used to verify phase rotation). Check all fuses and verify that all wiring connections are correct. If problems persist, contact your local Time Mark Distributor, or the factory for assistance (*Monday-Friday, 8 a. m. to 5 p. m. CST*).

MANUAL RESET VERSIONS

IF YOU DO NOT WISH TO USE THE EXTERNAL RESET SWITCH ON THE MANUAL RESET VERSION, YOU MUST JUMPER PINS 6 AND 7. Refer to the Manual Reset 8-pin diagram.

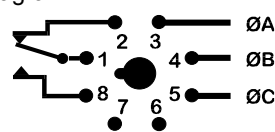

Automatic Reset

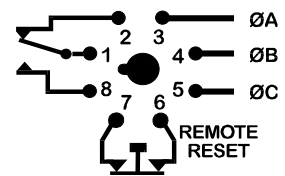

Manual Reset

WARRANTY

The **Model 257 3-Phase Monitor** is warranted to be free from defects in materials and workmanship, and is covered by our exclusive **5-year Unconditional Warranty**. If this device fails to operate, for any reason, we will repair or replace it free, for five years from the date of purchase. Contact the Time Mark Sales department, Monday through Friday; 8 a.m. to 5 p.m., CST, for further details.



TIME MARK
CORPORATION

Doc No. 87A189 12/00
© 2000 TIME MARK CORPORATION

TIME MARK is a division of  **AEMT, Inc.**